

TOP VIEW

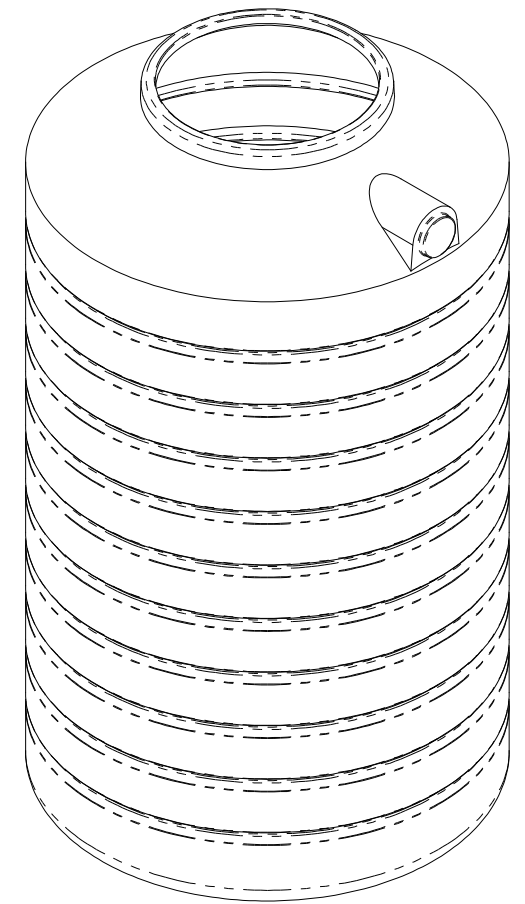

ISOMETRIC VIEW

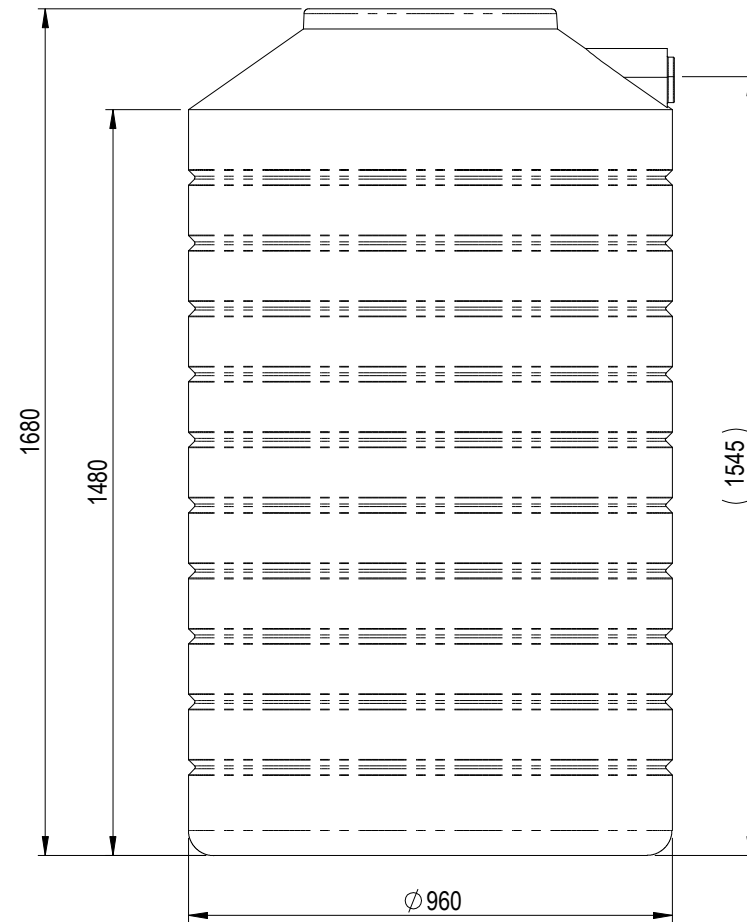

FRONT VIEW

ALL WELDING TO BE WELD CATEGORY GP U.N.O.
WELD CATEGORIES 'GP' AND 'SP' TO BE IN ACCORDANCE WITH AS1554 Pt 1 or 4.
REMOVE SHARP CORNERS, BURRS AND WELDSPATTER. BLEND DISCONTINUITIES.

ALL MACHINED SURFACES TO BE $\frac{3.2}{\sqrt{R}}$ U.N.O.
MACHINING TOLERANCES ARE $\pm 0.25\text{mm}$ UNLESS NOTED
FABRICATION TOLERANCES ARE $\pm 2\text{mm}$ UNLESS NOTED

PROTECT MACHINED SURFACES PRIOR
TO PAINTING. DIMENSIONS SHOWN () ARE
FOR REFERENCE ONLY

PE TOLERANCE
 $\pm 3\%$

Mass: kg

A	FOR CONSTRUCTION				
REV.	DESCRIPTION	DRAWN	APP'D	DATE	

THIS DRAWING REMAINS THE PROPERTY OF AUSTRALIAN WATER SYSTEMS AND MAY NOT BE MANUFACTURED FROM, COPIED OR TRANSMITTED TO A THIRD PARTY WITHOUT PRIOR APPROVAL FROM AUSTRALIAN WATER SYSTEMS



2/168 Wharf Street, Spring Hill, Qld, 4000
Phone: 07 3227 9777
Fax: 07 3831 7466
Web: www.australianwatersystems.com.au

DESIGN:	-	-
DRAWN:	DBain	04.05.10
APP'D:		

SCALE: 1:15
DO NOT SCALE

CT225
1000 ltrs

DRAWING NUMBER
CT225
SHEET: 1 of 1

SHEET SIZE
A3
REV
A0